

SEPARSAND SS

ALIMENTATION

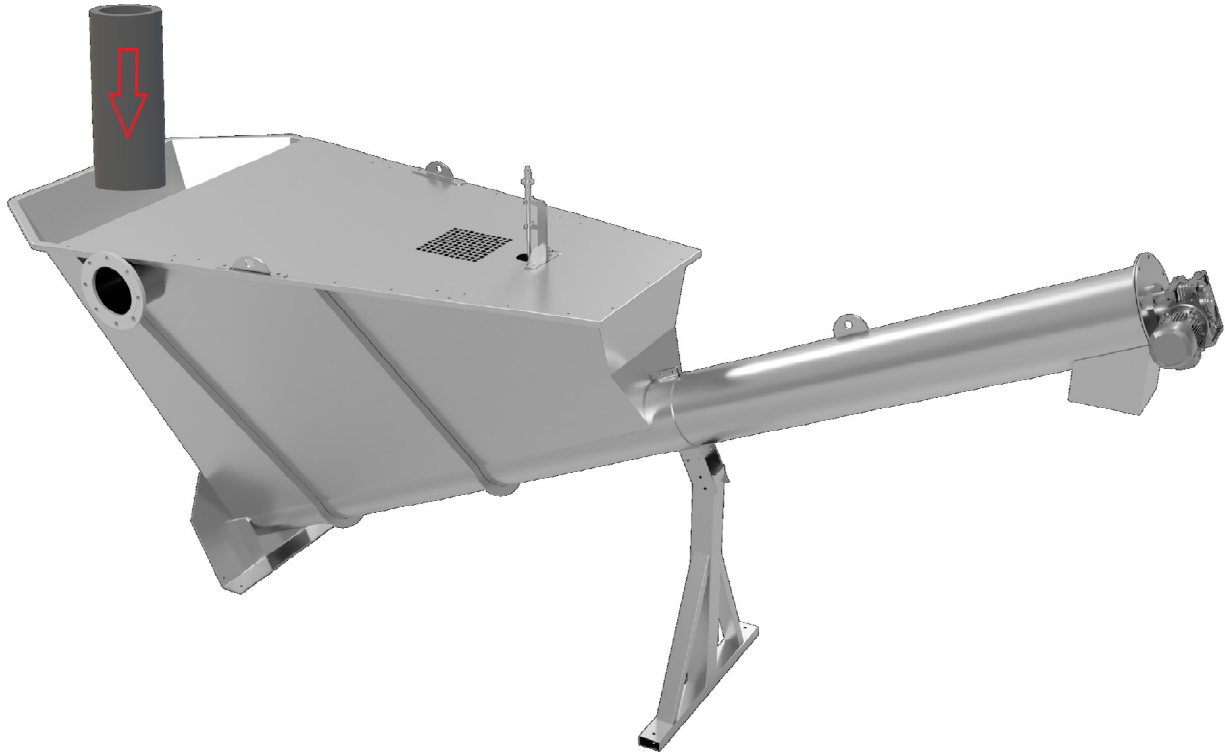

SEPARSAND (Model)	FLOW (l/min)
SS 600	600
SS 1000	1000
SS 1400	1400
SS 2000	2000

1. SOURCE OF THE WATER TO BE TREATED

--

2. FLOW RATE TO BE TREATED m³/h

--

3. CONTINUOUS OR DISCONTINUOUS FLOW

--