

ECOREJECT-V/ER

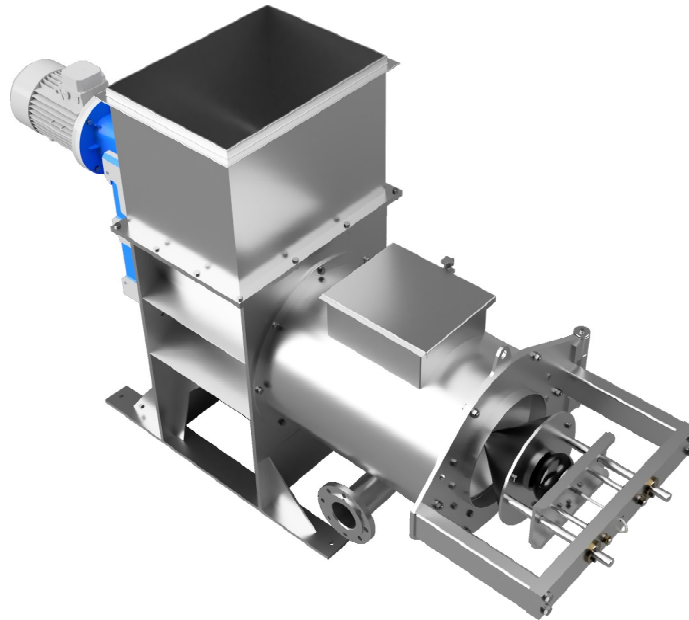

1. SOURCE MACHINE OF THE SUSPENSION TO BE TREATED
2. TYPE OF PASTE TREATED IN THE PLANT
3. MAXIMUM FLOW RATE OF THE SUSPENSION TO BE TREATED m³/h
4. CONTINUOUS OR DISCONTINUOUS FLOW
5. CONCENTRATION OF SOLIDS IN THE SUSPENSION % OF FIBRES AND % OF CONTAMINANTS
6. DEGREE OF CLEANLINESS THAT WE AIM TO ACHIEVE FROM THE THICKENING WATER OR ITS SUBSEQUENT UTILITY